

Dialogue Systems

NPFL123 Dialogové systémy

10. Text-to-speech Synthesis

Ondřej Dušek & Vojtěch Hudeček & Jan Cuřín

<http://ufal.cz/npfl123>

22. 4. 2020

Text-to-speech synthesis

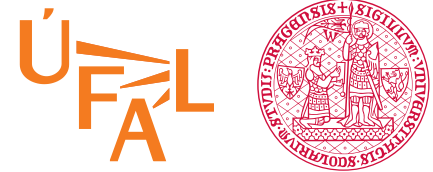

- Last step in DS pipeline
 - from NLG (system utterance text)
 - to the user (audio waveform)
- Needed for all but the simplest DSs
- Sequence-to-sequence conversion
 - from discrete symbols (letters)
 - to continuous time series (audio waves)
 - regression problem
 - mimicking human articulation in some way
- Typically a 2-step pipeline:
 - **text analysis** (frontend) – converting written to phonetic representation
 - **waveform synthesis** (backend) – phonemes to audio

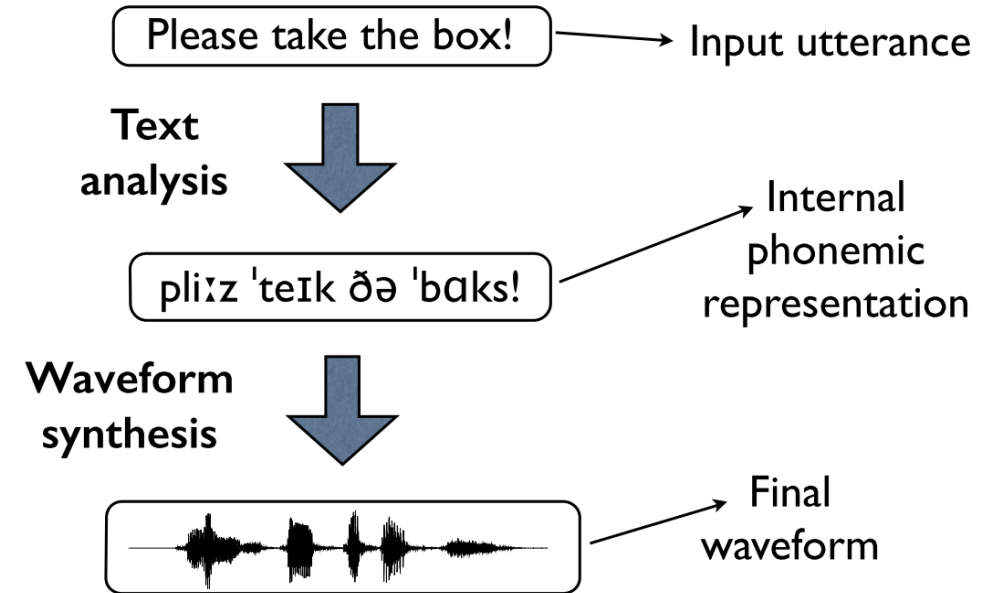

(from Pierre Lison's slides)

Human articulatory process

- text (concept) → movement of muscles → air movement (sound)
- source excitation signal = air flow from lungs
 - vocal cords resonance
 - base frequency (F0)
 - upper harmonic frequencies
 - turbulent noise
- frequency characteristics moderated by **vocal tract**
 - shape of vocal tract changes (tongue, soft palate, lip, jaw positions)
 - some frequencies resonate
 - some suppressed

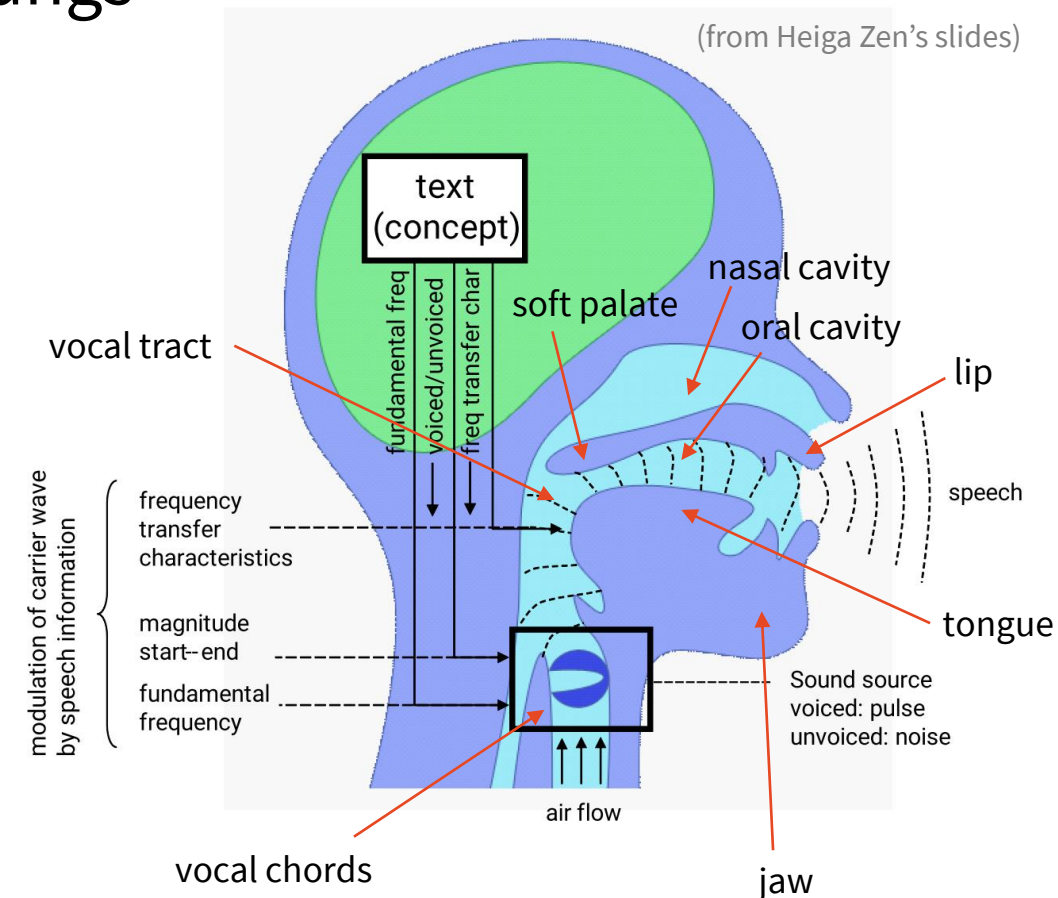

Sounds of Speech



- **phone/sound** – any distinct speech sound
- **phoneme** – sound that distinguishes meaning
 - changing it for another would change meaning (e.g. *dog* → *fog*)
- **vowel** – sound produced with open vocal tract
 - typically **voiced** (=vocal chords vibrate)
 - quality of vowels depends mainly on vocal tract shape
- **consonant** – sound produced with (partially) closed vocal tract
 - voiced/voiceless (often come in pairs, e.g. **[p]** – **[b]**)
 - quality also depends on type + position of closing
 - stops/plosives = total closing + “explosive” release (**[p]**, **[d]**, **[k]**)
 - nasals = stops with open nasal cavity (**[n]**, **[m]**)
 - fricatives = partial closing (induces friction – hiss: **[f]**, **[s]**, **[z]** ...)
 - approximants = movement towards partial closing & back, half-vowels (**[w]**, **[j]** ...)

Sounds of Speech

<http://www.ipachart.com/>
(clickable with sounds!)



Vowels

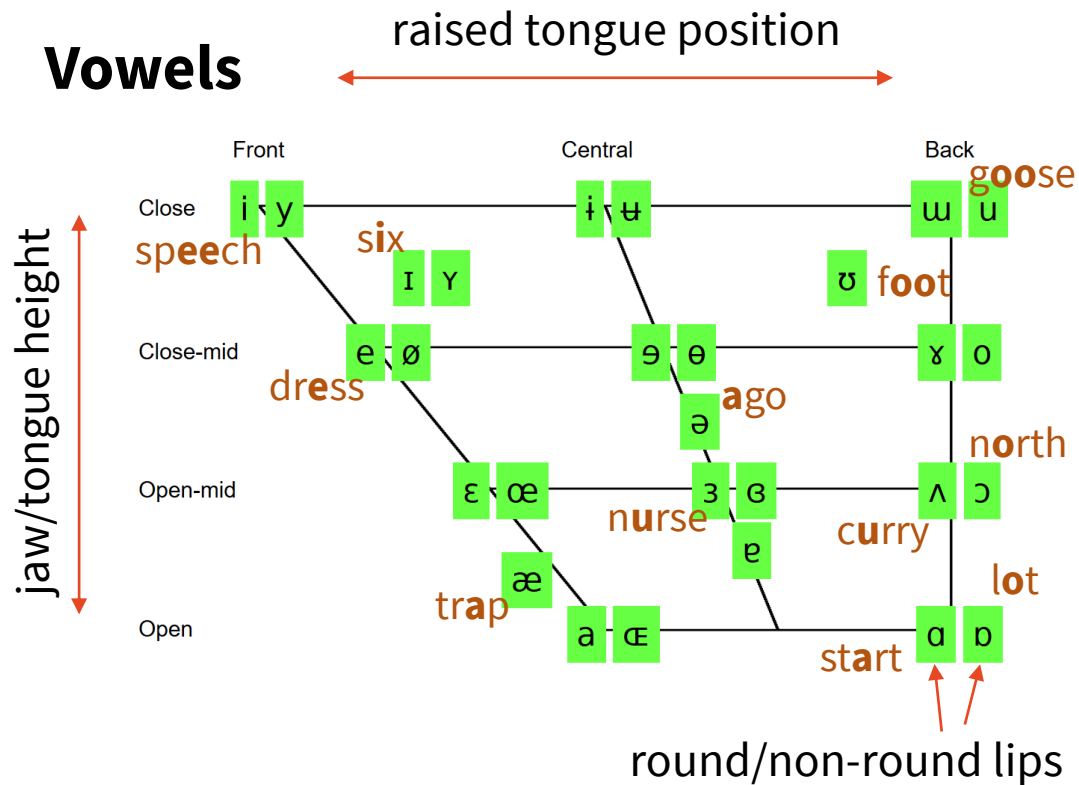

Consonants

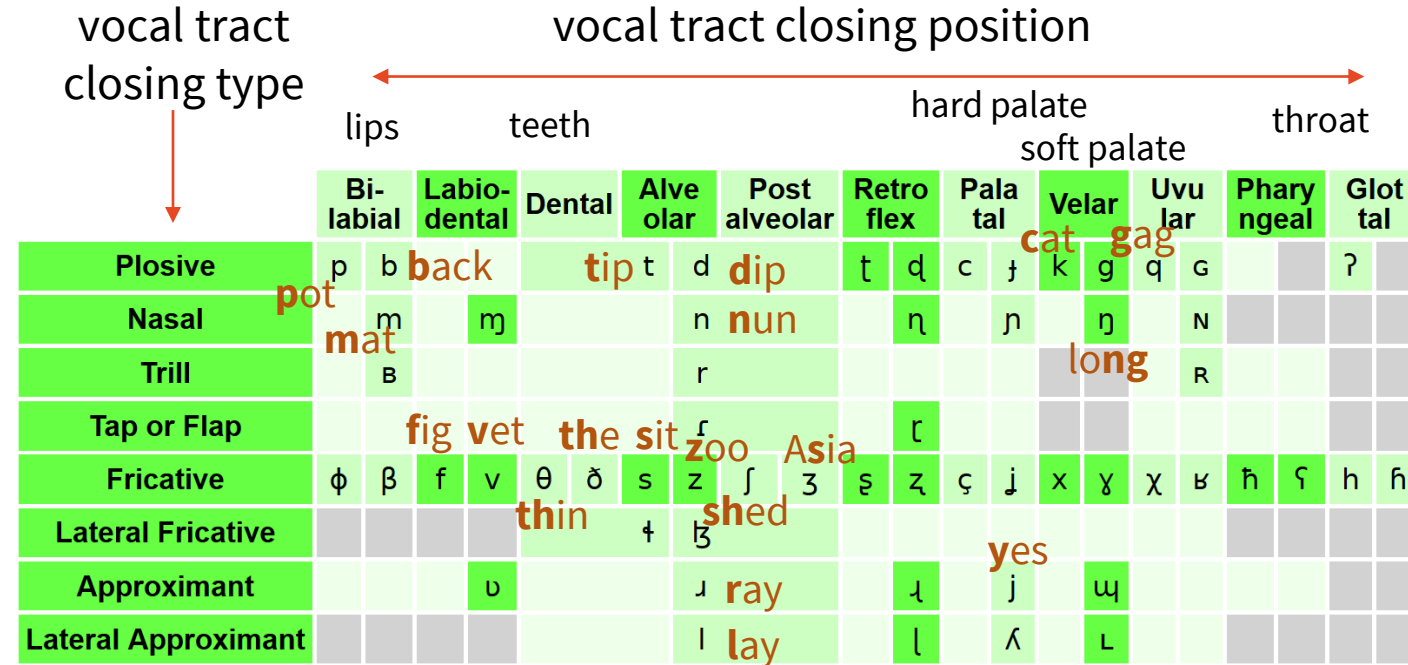

- Word examples according to Received Pronunciation (“Queen’s English”), may vary across dialects
- More vowels: diphthongs (changing jaw/tongue position, e.g. [ei] *wait*, [əʊ] *show*)
- More consonants: affricates (plosive-fricative [tʃ] *chin*, [dʒ] *gin*), labio-velar approximant [w] *well*

Spectrum

- speech = compound wave
 - different frequencies (spectrum)
 - shows in a **spectrogram**
 - frequency – time – loudness
- base vocal cord frequency **F0**
 - present in voiced/vocals
 - absent in voiceless
- **formants** = loud upper harmonics
 - of base vocal cord frequency
 - F1, F2 – 1st, 2nd formant
 - distinctive for vowels
- noise – broad spectrum
 - consonants (typical for fricatives)

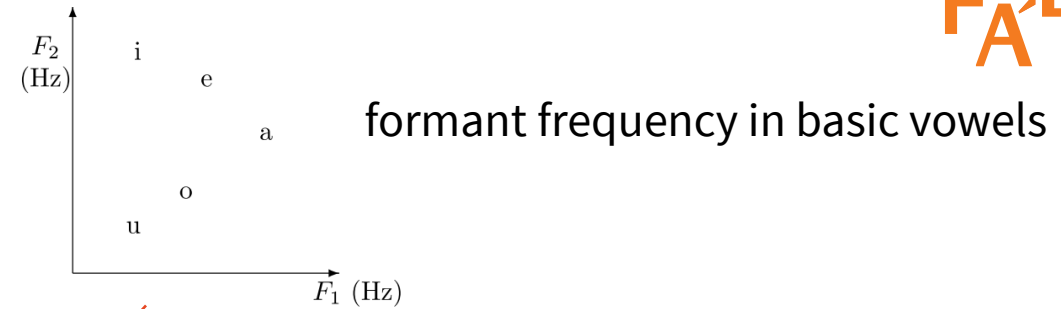

plosive = stop (silence) + explosion (short noise)

fricative = noise

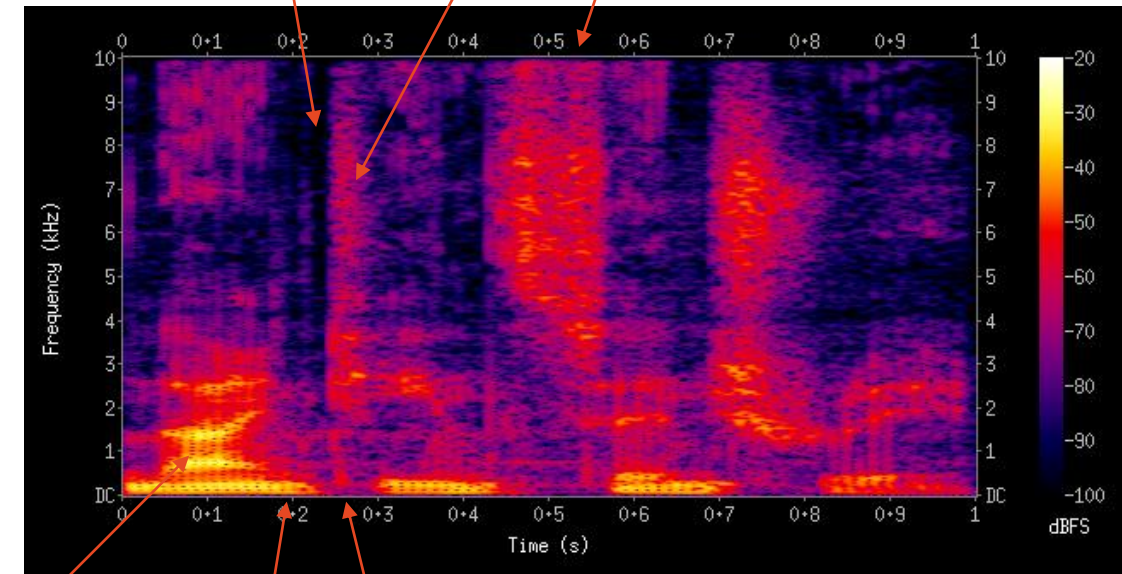

diphthong
– moving formants

voiced

voiceless

From sounds to utterances



- phones group into:
 - **syllables** – minimal pronounceable units
 - **stress units** (~ words) – group of syllables with 1 stressed
 - **prosodic/intonation units** (~ phrases)
 - independent prosody (single prosodic/pitch contour)
 - tend to be separated by pauses
 - utterances (~ sentences, but can be longer)
- neighbouring phones influence each other a lot!
- **stress** – changes in timing/F0 pitch/intensity (loudness)
- **prosody/melody** – F0 pitch
 - sentence meaning: question/statement
 - tonal languages: syllable melody distinguishes meaning



https://en.wikipedia.org/wiki/Prosodic_unit

TTS Prehistory

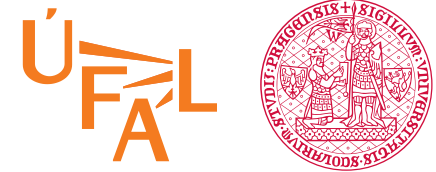

- 1st mechanical speech production system
 - Wolfgang von Kempelen's speaking machine (1790's)
 - model of vocal tract, manually operated
 - (partially) capable of monotonous speech
- 1st electric system – Voder
 - Bell labs 1930, operated by keyboard (very hard!)
 - pitch control
- 1st computer TTS systems – since 1960's
- Production systems – since 1980's
 - e.g. DECTalk (a.k.a. Stephen Hawking's voice)

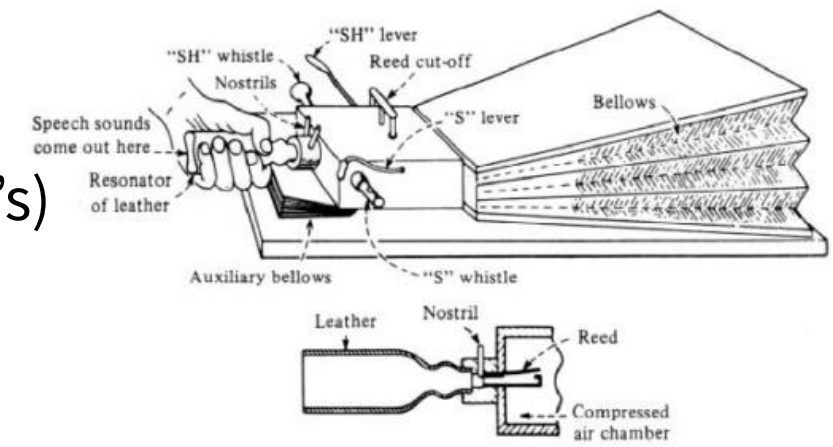

(Lemmetty, 1999)
https://youtu.be/k_YUB_S6Gpo?t=67

<https://youtu.be/8pewe2gPDk4?t=8>

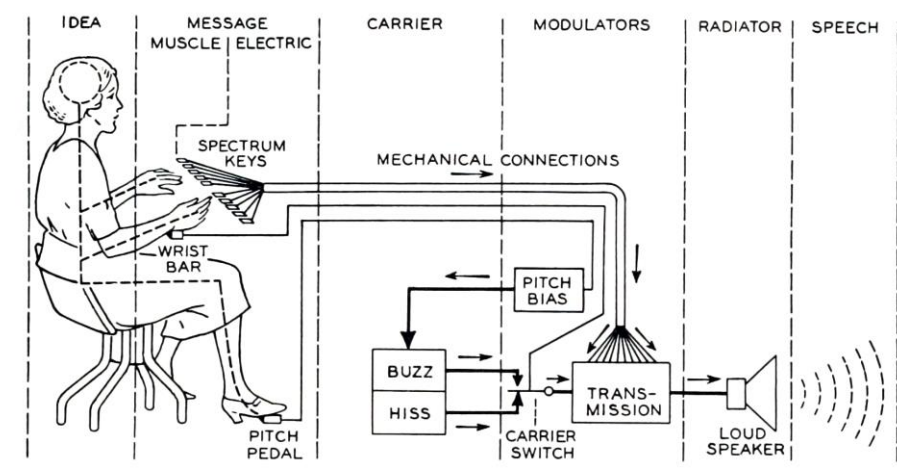
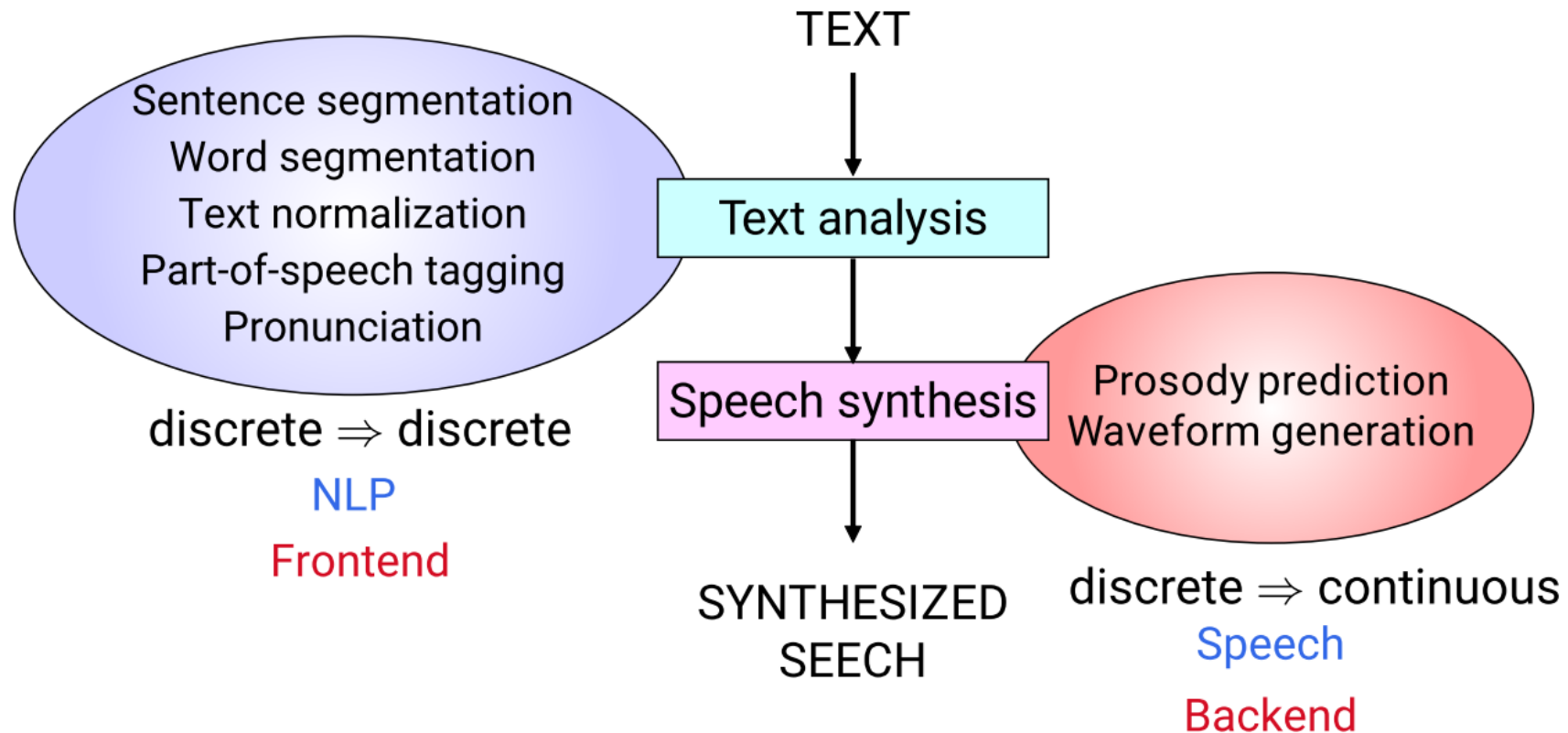

Fig. 8—Schematic circuit of the voder.

<https://en.wikipedia.org/wiki/Voder>
https://youtu.be/TsdOej_nC1M?t=36

TTS pipeline

- frontend & backend, frontend composed of more sub-steps
 - frontend typically language dependent, but independent of backend



Segmentation & normalization

- remove anything not to be synthesized
 - e.g. HTML markup, escape sequences, irregular characters
- segment sentences
- segment words (Chinese, Japanese, Korean scripts)

- spell out:

- abbreviations (context sensitive!)
- dates, times
- numbers (ordinal vs. cardinal, postal codes, phone numbers...)
- symbols (currency, math...)

Tue Apr 5 → Tuesday April fifth
€ 520 → five hundred and twenty euros

- all typically rule-based

432 Dr King Dr → four three two doctor king drive
1 oz → one ounce
16 oz → sixteen ounces

Grapheme-to-Phoneme Conversion



- main approaches: pronouncing dictionaries + rules
 - rules good for languages with regular orthography (Czech, German, Dutch)
 - dictionaries good for irregular/historical orthography (English, French)
 - typically it's a combination anyway
 - rules = fallback for out-of-vocabulary items
 - dictionary overrides for rules (e.g. foreign words)
 - can be a pain in a domain with a lot of foreign names
 - you might need to build your own dictionary (even with a 3rd-party TTS)
- phonemes typically coded using ASCII (SAMPA, ARPABET...)
- pronunciation is sometimes context dependent
 - part-of-speech tagging
 - contextual rules

phoneme
[ˈfəʊni:m]
f@Uni:m
F O W N I Y M

the oak = [ði:ˈəʊk]
the one = [ðəˈwʌn]

record (NN) = [ˈrɛko:d] *read* (VB) = [ˈri:d]
record (VB) = [rɪˈko:d] *read* (VBD) = [rɛd]

Intonation/stress generation



- rules/statistical
 - predicting intensity, F0 pitch, speed, pauses
 - stress units, prosody units
 - language dependent
 - traditionally: classification – bins/F0 change rules
- based on:
 - punctuation (e.g. “?”)
 - chunking (splitting into intonation units)
 - words (stressed syllables)
 - part-of-speech tags (some parts-of-speech more likely to be stressed)
 - syntactic parsing

SSML (Speech Synthesis Markup Language)



- manually controlling pronunciation/prosody for a TTS
 - must be supported by a particular TTS
 - e.g. Alexa supports this (a lot of other vendors, too)
- XML-based markup:
 - `<break>`
 - `<emphasis level="strong">`
 - `<lang>`
 - `<phoneme alphabet="ipa" ph="ba.təl">`
 - `<prosody rate="slow">`, `<prosody pitch="+15.4%">`, `<prosody volume="x-loud">`
 - `<say-as interpret-as="digits">` (date, fraction, address, interjection...)
 - `_{subst}` (abbreviations)
 - `<voice>`
 - `<w role="amazon:VBD">read</w>` (force part-of-speech)

Waveform Synthesis

- many different methods possible
- **formant-based** (~1960-1980's)
 - rule-based production of formants & other components of the wave
- **concatenative** (~1960's-now)
 - copy & paste on human recordings
- **parametric** – model-based (2000's-now)
 - similar to formant-based, but learned from recordings
 - HMMs – dominant approach in the 2000's
 - NNs – can replace HMMs, more flexible
- NN-based **end-to-end methods**
 - now emerging

Rule-based, formant synthesis [1]

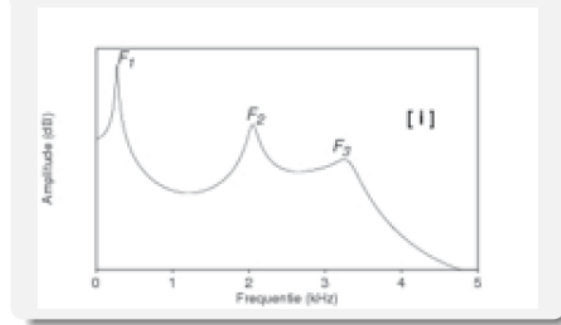

Sample-based, concatenative synthesis [2]

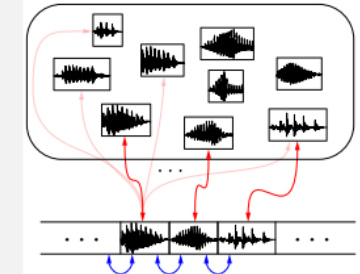

Model-based, generative synthesis

$p(\text{speech} = \text{[audio waveform]} \mid \text{text} = \text{"Hello, my name is Heiga Zen."})$

(from Heiga Zen's slides)

Formant-based Synthesis

- early systems
- based on careful handcrafted analysis of recordings
 - “manual” system training
 - very long evolution – DECtalk took ~20 years to production
 - barely intelligible at first
- rules for composing the output sound waves
 - based on formants resonators + additional components
 - rules for sound combinations (e.g. “b before back rounded vowels”)
 - rules for suprasegmentals – pitch, loudness etc.
- results not very natural, but very intelligible in the end
- very low hardware footprint

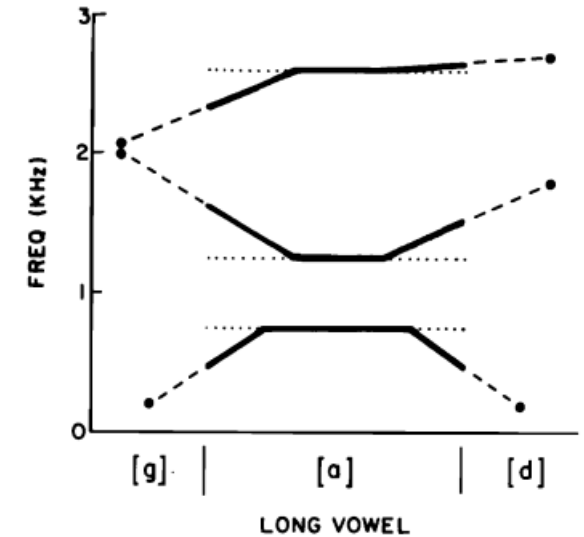

(Klatt, 1987)

Holmes et al., 1964



DECtalk, 1986



Concatenative Synthesis



- Cut & paste on recordings
 - can't use words or syllables – there are too many (100k's / 10k)
 - can't use phonemes (only ~50!) – too much variation
 - **coarticulation** – each sound is heavily influenced by its neighbourhood
- using **diphones** = 2nd half of one phoneme & 1st half of another
 - about 1,500 diphones in English – manageable
 - this eliminates the heaviest coarticulation problems (but not all)
 - still artefacts at diphone boundaries
- smoothing/overlay & F0 adjustments
 - over-smoothing makes the sound robotic
 - pitch adjustments limited – don't sound natural
- needs lots of recordings of a single person
- diphone representations: formants, LPC, waveform

Dixon & Maxey (1968)
formant diphones



Olive (1977)
LPC diphones



Festival (1997)
diphone synthesis



<http://www.cstr.ed.ac.uk/projects/festival/>

MBROLA (1996)

<http://tcts.fpms.ac.be/synthesis/>



Unit-selection Concatenative Synthesis



- using more instances of each diphone
 - minimize the smoothing & adjustments needed
- selecting units that best match the target position
 - match target pitch, loudness etc. (specification s_t) – **target cost** $T(u_t, s_t)$
 - match neighbouring units – **join cost** $J(u_t, u_{t+1})$
 - looking for best sequence $\hat{U} = \{u_1, \dots, u_n\}$, so that:

$$\hat{U} = \arg \min_U \sum_{t=1}^n T(u_t, s_t) + \sum_{t=1}^{n-1} J(u_t, u_{t+1})$$

- solution: **Viterbi search**
- leads to joins of stuff that was recorded together
- a lot of production systems use this
 - still state-of-the-art for some languages
 - but it's not very flexible, requires a lot of single-person data to sound good

Festival
unit-selection



MARY TTS
unit selection



IBM Watson
concatenative



Google concatenative



http://www.cs.cmu.edu/~awb/festival_demos/general.html

<http://mary.dfki.de/>

<https://text-to-speech-demo.ng.bluemix.net/>

<https://deepmind.com/blog/wavenet-generative-model-raw-audio/>

Model-based Parametric Synthesis



- trying to be more flexible, less resource-hungry than unit selection
- similar approach to formant-based – modelling
 - but this time learned statistically from a corpus
- inverse of model-based ASR (last lecture)
- ideal: model $p(x|w, X, W)$
 - auxiliary representations – features
 - approximate by step-by-step maximization:
 - 1) extract features from corpus (acoustic, linguistic)
 - 2) learn model based on features
 - 3) predict features given text (linguistic, then acoustic)
 - 4) synthesize given features

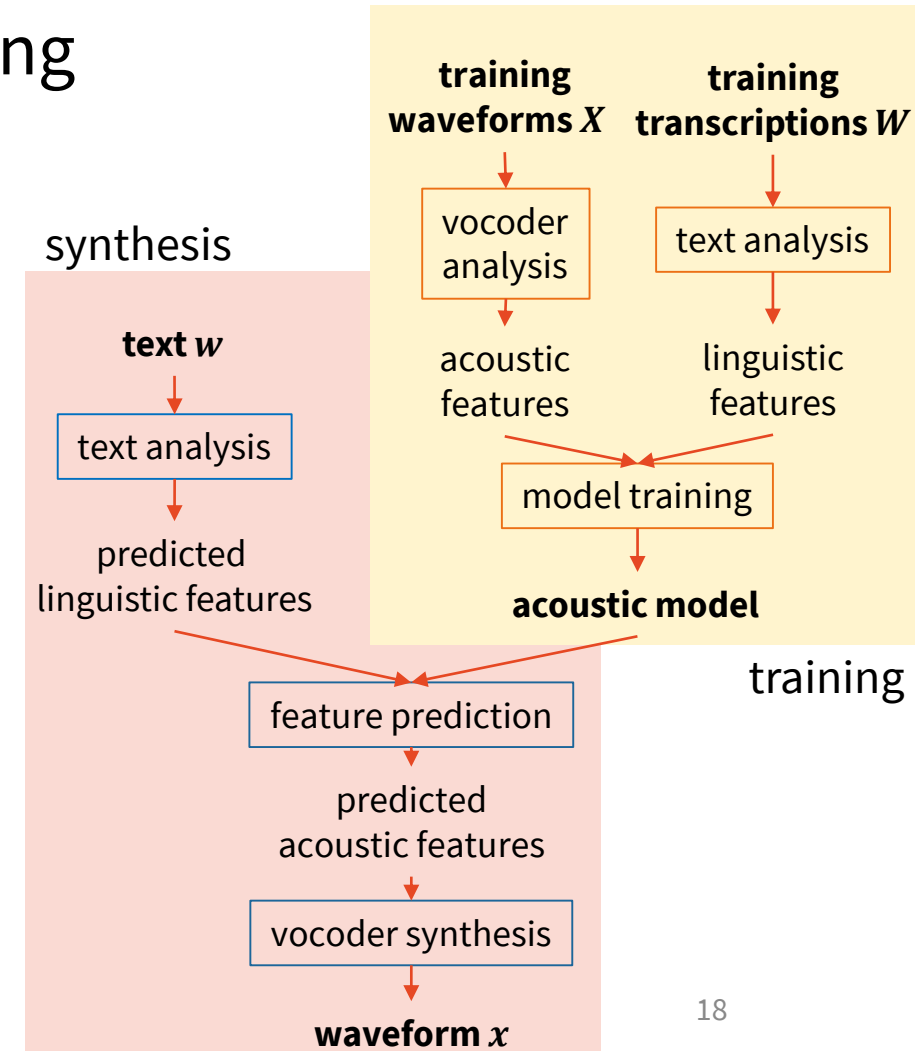

Features for model-based synthesis

- Acoustics: piecewise stationary source-filter model
 - spectrum (filter/resonance frequencies): typically MFCCs, Δ , $\Delta\Delta$
 - excitation (sound source): voiced/unvoiced, $\log F_0$, Δ , $\Delta\Delta$

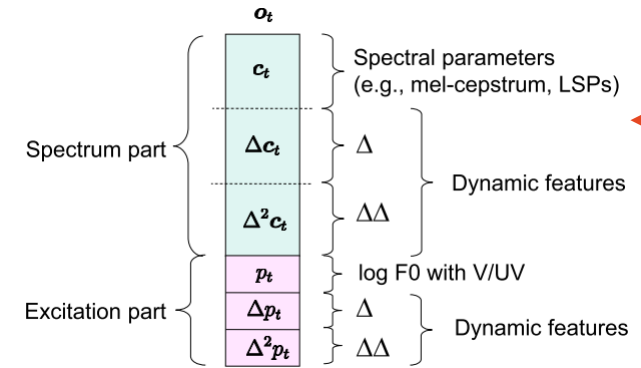
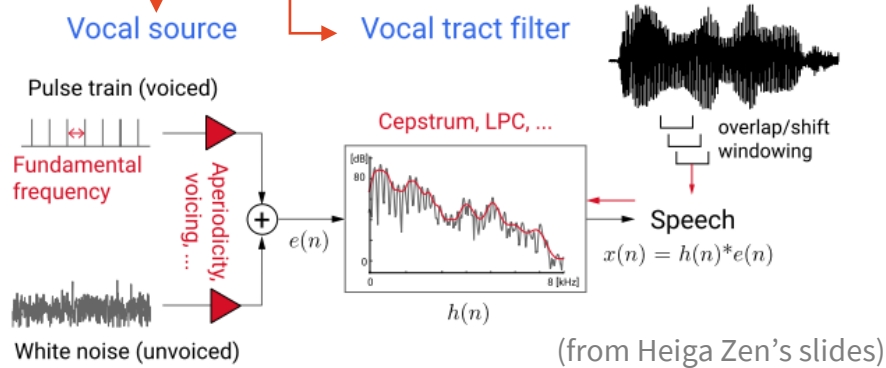

(Tokuda et al., 2013)

- Linguistics:
 - phonemes
 - stress
 - pitch

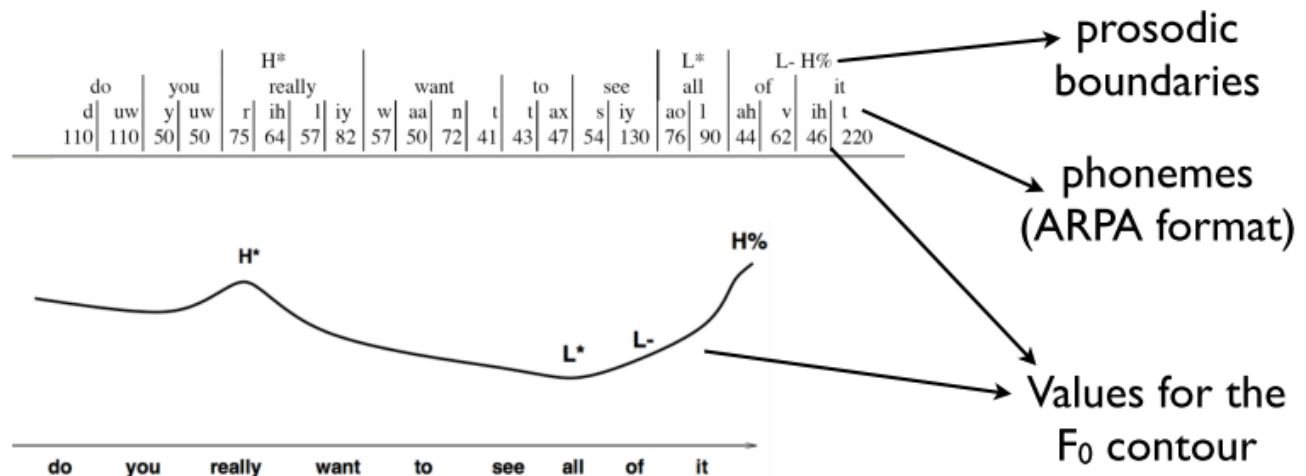

(from Pierre Lison's slides)

HMM-based Synthesis

- Using HMMs as the speech model
- Context-dependent phoneme-level HMMs
 - concatenated into a big utterance-level HMM
 - transition & emission probabilities – multivariate Gaussian distributions
 - loops – handling different phoneme lengths
- Too many possible contexts → use decision-tree-based clustering
 - ~10M possible context combinations
 - regression trees (outputs = real-valued Gaussian parameters)
- Generating from this would result in step-wise sequence
 - sample from each Gaussian, wait a few ms, sample...
 - → this is where Δ , $\Delta\Delta$ are used

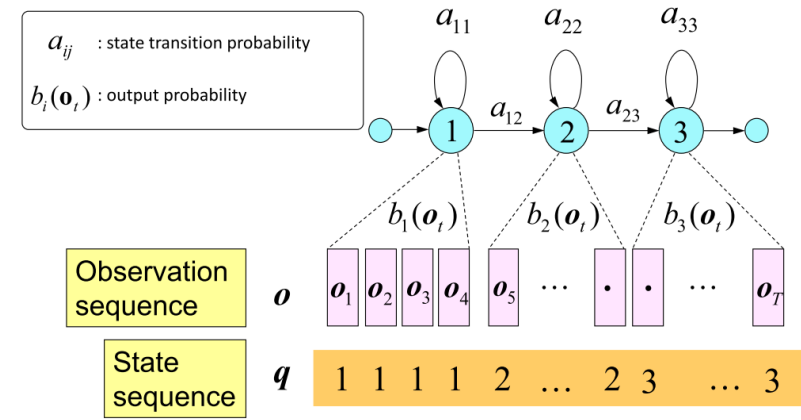

(Tokuda et al., 2013)

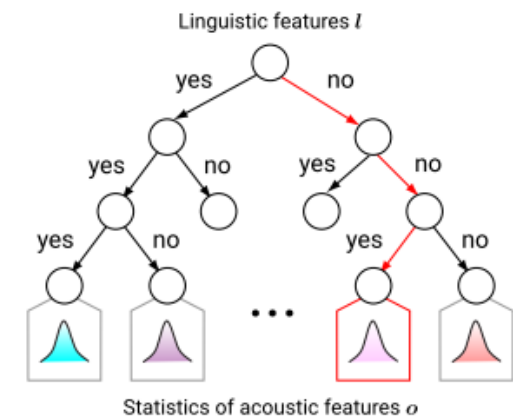

(from Heiga Zen's slides)

HMM-based Synthesis

- Pros vs. concatenative:
 - small data footprint
 - robust to data sparsity
 - flexible – can change voice characteristics easily
- Con:
 - lowered segmental naturalness

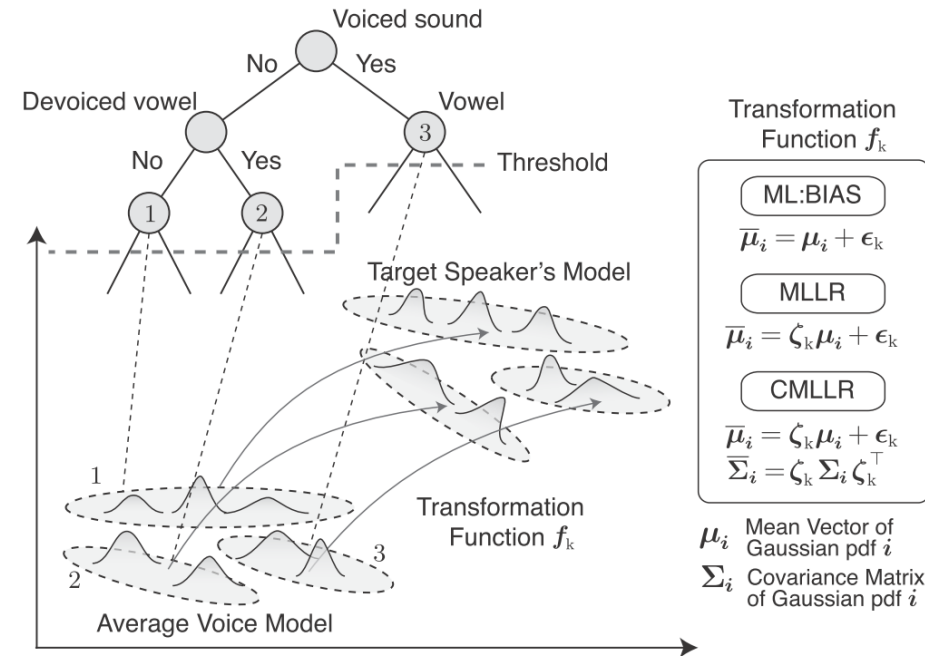

(Tokuda et al., 2013)

FLite/HTS
(various settings)



<http://flite-hts-engine.sp.nitech.ac.jp/index.php>

MARY TTS
HSMM-based



<http://mary.dfki.de/>

NN-based synthesis



- Replacing clunky HMMs and decision trees with NNs
- Basic – feed forward networks
 - predict conditional expectation of acoustic features given linguistic features at current frame
 - trained based on mean squared error
- Improvement – RNNs
 - same, but conditioned on current & previous frames
 - predicts smoother outputs (given temporal dependencies)
- NNs allow better features (e.g. raw spectrum)
 - more data-efficient than HMMs
- This is current production quality TTS

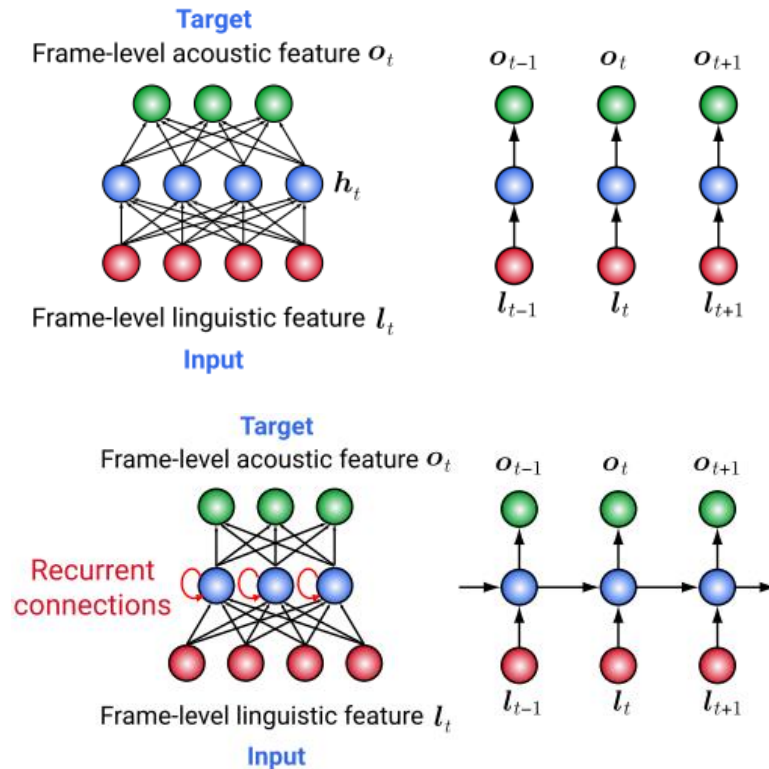

(from Heiga Zen's slides)

Google LSTM parametric



IBM Watson DNN



WaveNet

(van den Oord et al., 2016)
<https://arxiv.org/abs/1609.03499>
<https://deepmind.com/blog/wavenet-generative-model-raw-audio/>



- Removing acoustic features – direct waveform generation
 - no need for cepstrum, frames etc.
- Based on convolutional NNs
 - 16k steps/sec → need very long dependencies
 - **dilated convolution** – skipping steps
 - exponential receptive field w.r.t. # of layers
 - conditioned on linguistic features
 - predicting quantized waves using softmax
- Not tied to \pm stationary frames
 - can generate highly non-linear waves
- Very natural, Google's top offering now

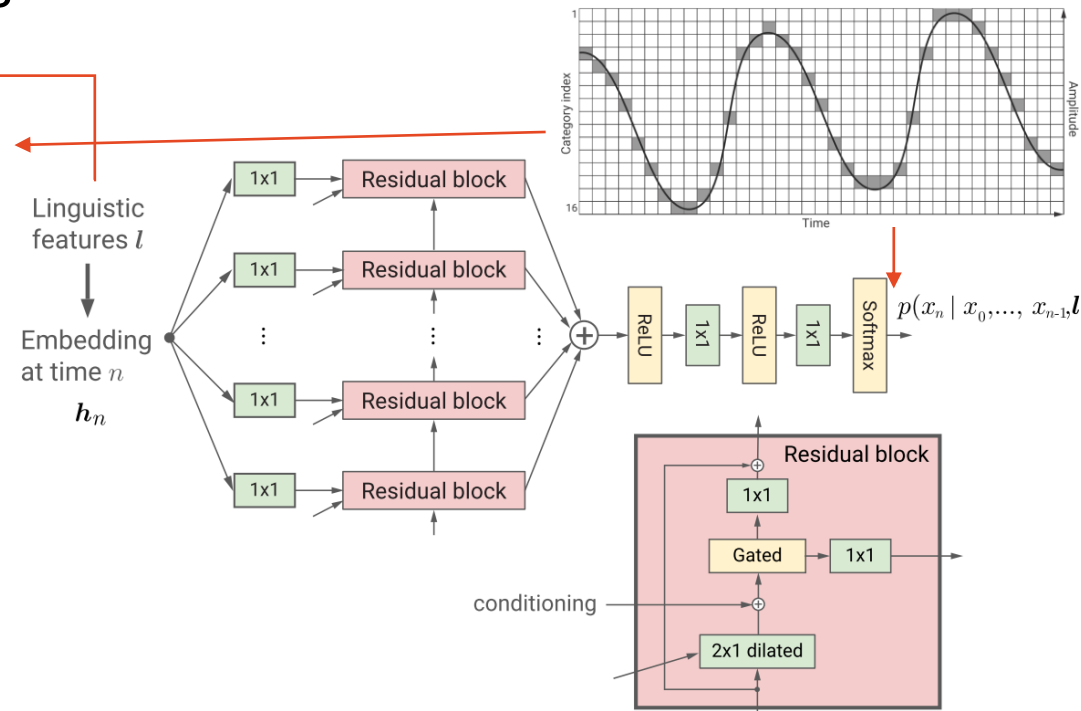
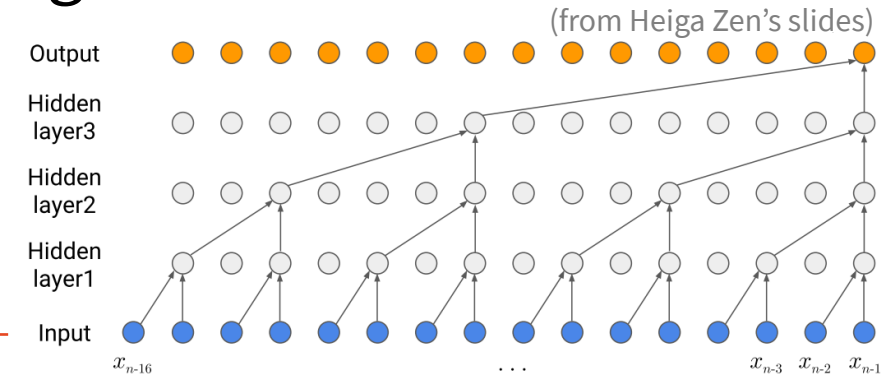

Google WaveNet



Tacotron

(Wang et al., 2017)
<https://arxiv.org/abs/1703.10135>
<https://google.github.io/tacotron/>



- Different approach: removing linguistic features
 - can be trained directly from pairs of waveforms & transcriptions
 - generates linear scale spectrograms (at frame level)
 - Griffin-Lim conversion: spectrogram → waveform
 - estimate the missing wave phase information
- Based on seq2seq models with attention
 - encoder – CBHG (1D convolution + highway net + GRU)
 - decoder – seq2seq predicts mel-scale spectrograms, r steps at a time
 - neighbouring frames in speech are correlated
 - postprocessing – to linear scale
 - access to whole decoded sequence
- Very natural outputs

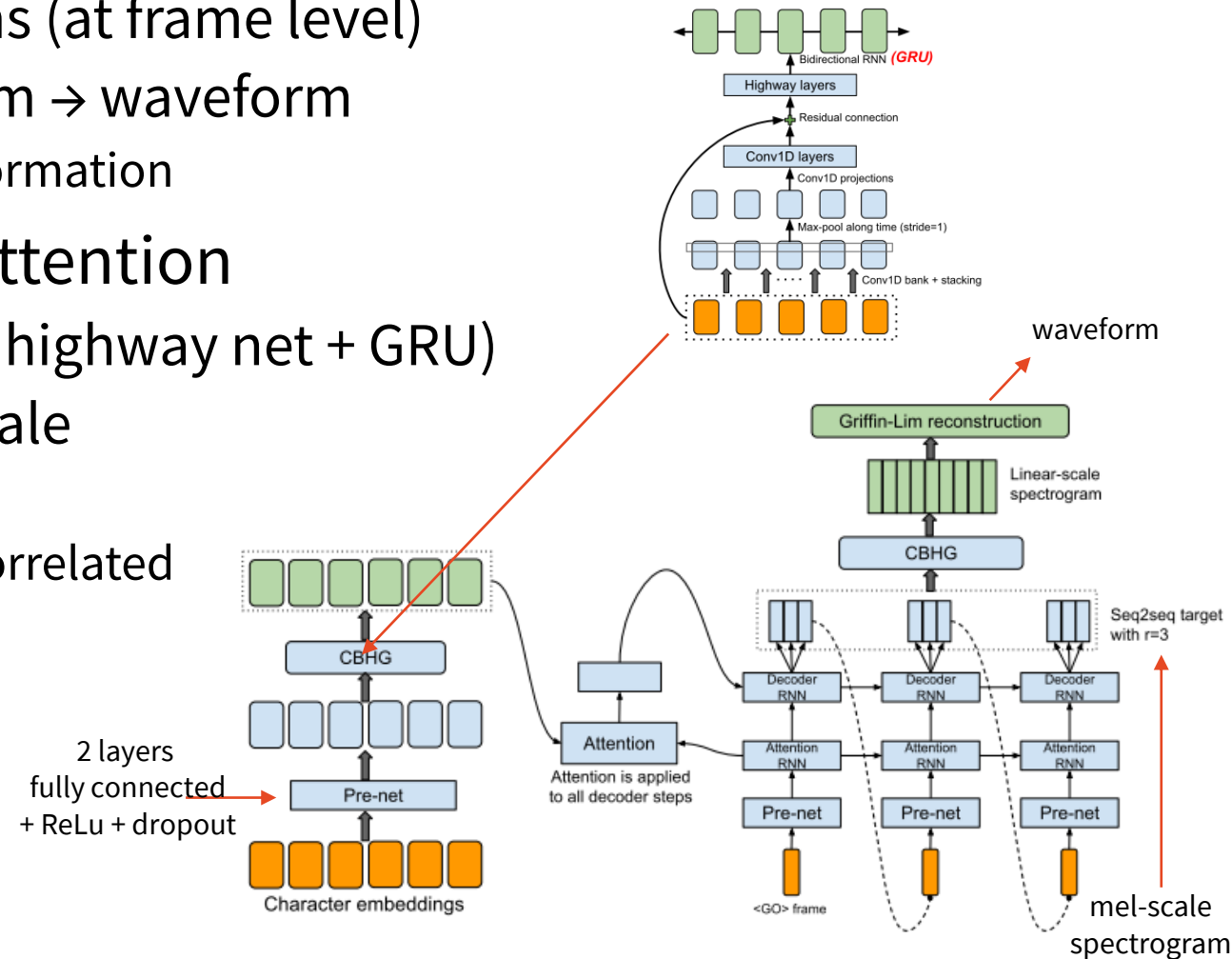

Summary



- Speech production
 - “source-filter”: air + vocal cords vibration + resonance in vocal tract
 - sounds/phones, phonemes
 - consonants & vocals
 - spectrum, formants
 - pitch, stress
- Text-to-speech system architectures
 - rule/formant-based
 - concatenative – diphone, unit selection
 - model-based parametric: HMM, NNs
 - WaveNet
 - Tacotron

Thanks

Contact us:

odusek@ufal.mff.cuni.cz
hudecek@ufal.mff.cuni.cz
or Slack

Get these slides here:

<http://ufal.cz/npfl123>

References/Inspiration/Further:

- Heiga Zen's lecture (MIT 2017): <https://ai.google/research/pubs/pub45882>, <https://youtu.be/nsrSrYtKkT8>
- Tokuda et al. (2013): Speech synthesis based on Hidden Markov Models: <http://ieeexplore.ieee.org/document/6495700/>
- Pierre Lison's slides (Oslo University): <https://www.uio.no/studier/emner/matnat/ifi/INF5820/h14/timeplan/index.html>
- Dennis H. Klatt (1987): Review of text-to-speech conversion for English: <http://asa.scitation.org/doi/10.1121/1.395275>
- Heiga Zen's lecture (ASRU 2015): <https://ai.google/research/pubs/pub44630>
- Kathariina Makhonen's lecture notes (Tampere University): http://www.cs.tut.fi/kurssit/SGN-4010/puhesynteesi_en.pdf
- Raul Fernandez's lecture (2011): http://www.cs.columbia.edu/~ecooper/tts/SS_Lecture_CUNY_noaudio.pdf
- Sami Lemmetty's MSc. thesis (Helsinki Tech, 1999):
http://research.spa.aalto.fi/publications/theses/lemmetty_mst/thesis.pdf
- BBC Radio 4 – Lucy Hawking on TTS history (2013): <https://youtu.be/097K1uMIPyQ>

